

UNIVERSAL



**INOXMIAN** S.L.U.  
SINCE 1987

## Functions

This compact piece of machine is easy to install, start and operate. For each batch, it performs simultaneously grinds the cocoa, sugar and thoroughly blends the ingredients and refines them as required, in addition to conching the resulting chocolate mass.

## Technologies

The machine works by means of rotating blades that provide pressure against the inner wall of the working chamber. This working chamber is fitted with grooved sections, used by the rollers to mix and refine the product as required. The blades are moved by means of a meticulously designed reduction gear that enables maximum energy transfer with minimum consumption. The amount of pressure exerted by the blades against the grooved sections is determined by means of an electronically controlled and regulated hydraulic motor. The machine is fitted with a double-jacket for heating and cooling, as well as the corresponding resistances, controlled automatic cold water inlet and water pump to ensure an even distribution of operating temperatures.

## Advantages

Both blades and grooved sections are easy to remove and changeable. The control panel is equipped with a PLC to regulate the operating parameters, as well as enable diverse functions warnings and alarms. The machine is extremely easy to operate and offers easy access for cleaning and maintenance. It is suitable for the production of a wide range of manufactured products, such as chocolate, substitutes, compounds, pralines, special coating and fillings, as well as the recovery and recycling of rejects from other product lines

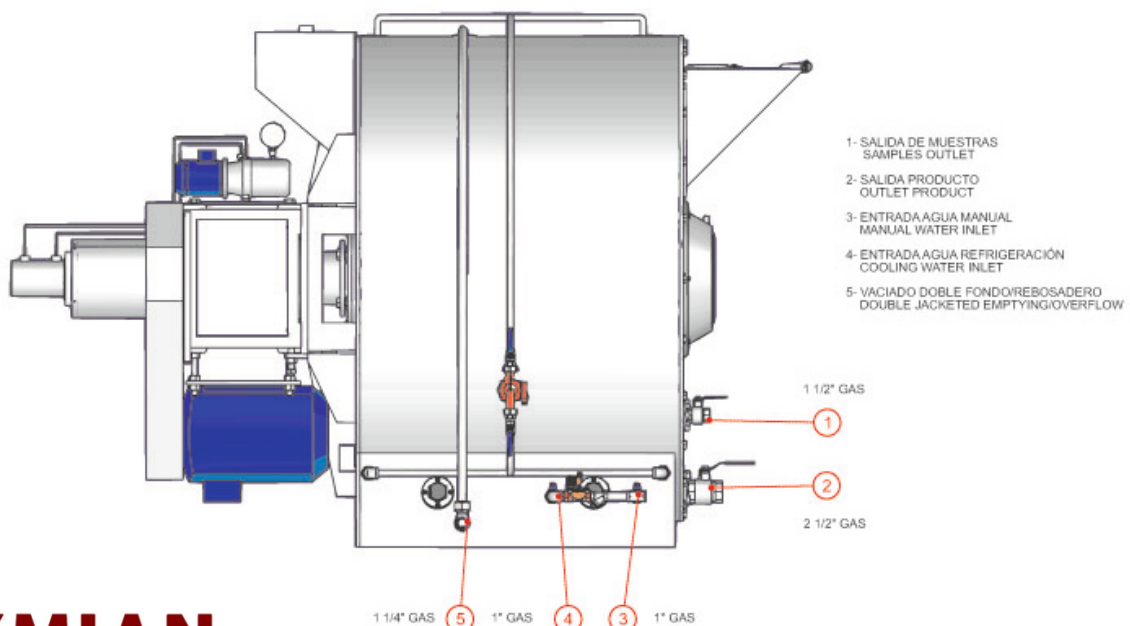

# Characteristics

	UNIX-20	UNIX-60	UNIX-200	UNIX-500	UNIX-1000	UNIX-1500	UNIX-3000
Capacity (kg)	20	60	200	500	1000	1500	3000
Motor (kW)	1,5	3	7,5	15	18,5	22	30
Heating (kW)	0,75	1	3	3	4,5	9	12
Cooling water consumption (lts/h)	250/300	300/400	500/700	750/1000	1500/1800	1500/1800	2000/2500
Length (mm)	1200	1650	1950	2280	2460	2850	3125
Width (mm)	550	680	1050	1200	1450	1820	2025
Height (mm)	660	850	1400	1520	1740	1940	2275
Weight (kg)	295	480	1650	2450	3350	6000	8500

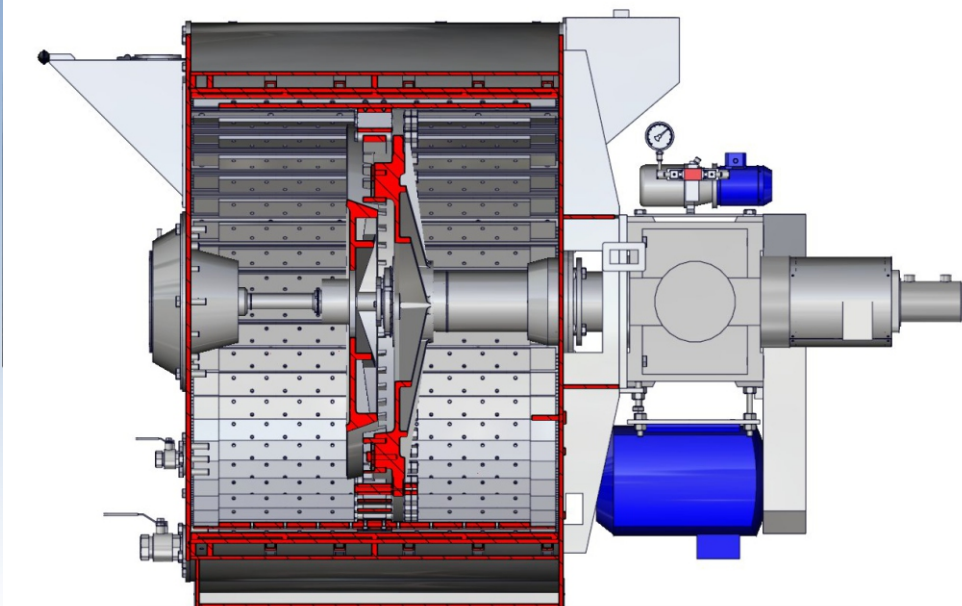
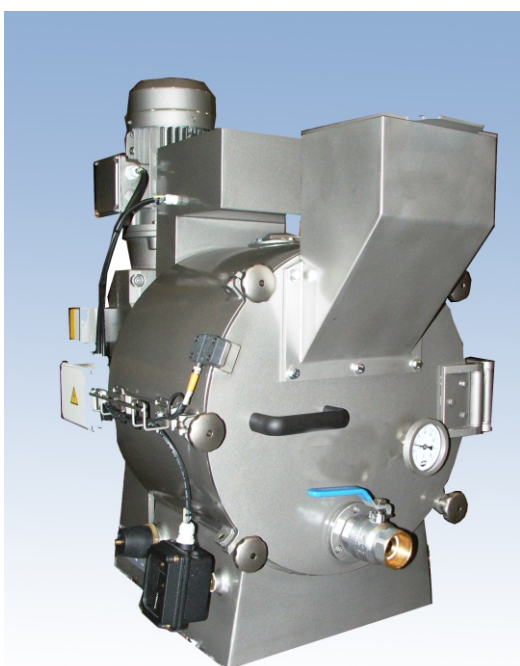

INOXMIAN, S.L.U.

C/Terra Alta 67-69  
 Polígono Industrial Can Carner  
 Castellar del Vallès (Barcelona)

Phone: +34 93 714 86 54  
 Fax: +34 93 714 88 06

e-mail: [serrano@inoxmian.com](mailto:serrano@inoxmian.com)

N 41° 35.814' E 2° 05.155'