



DEPOSITOR, WIRE-CUTTER EXTRUDER

# COMBY





COMBY<sup>3</sup> SD 400/460/600

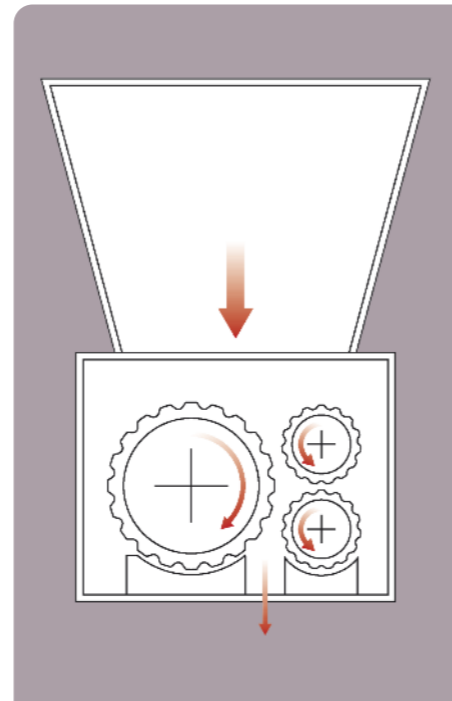

The COMBY3 can extrude, deposit or wire cut while processing an endless variety of recipes with remarkable versatility. These features are provided through the increased strength and sensitivity of the only depositing head that utilizes three stainless steel rollers. This design is engineered to supply unbeatable performance, consistency and reliability.





## COMBY<sup>3</sup> PLUS 600



MINIPAN present a new category of depositor and wirecut machine for biscuit, cookies and gluten free products: COMBY PLUS. It features a new design for easy sanitation, where extruding head can be removed from main frame, while motorization and electronics will remain in place. All movements are servodriven controlled.





Motorized rotating mould for dropped 800/1200

Mould for dropped products 800/1200

Wirecut mould 800/1200

COMBY<sup>3</sup> PLUS 800/1000/1200

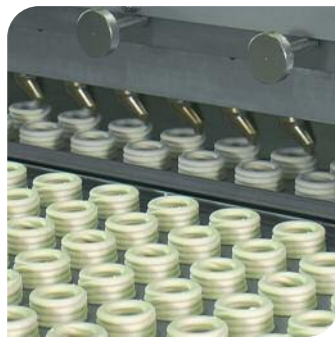

The heavy duty COMBY PLUS cookie production line with extruding head up to 1200 with versions for tunnel oven and deposit on trays





# DROPPED PRODUCTS

Standard mould for dropped products



Customized mould for dropped products sample



Customized Plumcake cup filling moulds\*

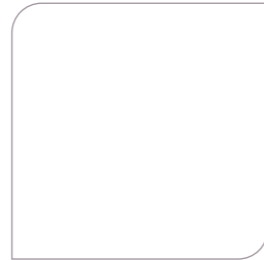

Motorized peak squashing device

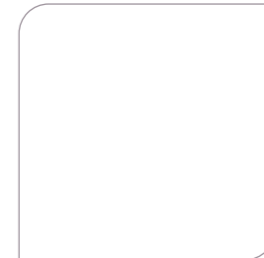



DROPPED PRODUCTS WITH MOTORIZED ROTATING MOULD



Customized smooth and grooved angled nozzles



DROPPED PRODUCTS WITH MOTORIZED SLUICE GATE MOULD



Dedicated sluice gate moulds for sponge cake

Dedicated sluice gate moulds for muffin trays\*





# PLATE MOULDS FOR DROPPED PRODUCTS

Bar holder for plate moulds



Customized plate moulds



# WIRE-CUT PRODUCTS

Wire-cut mould

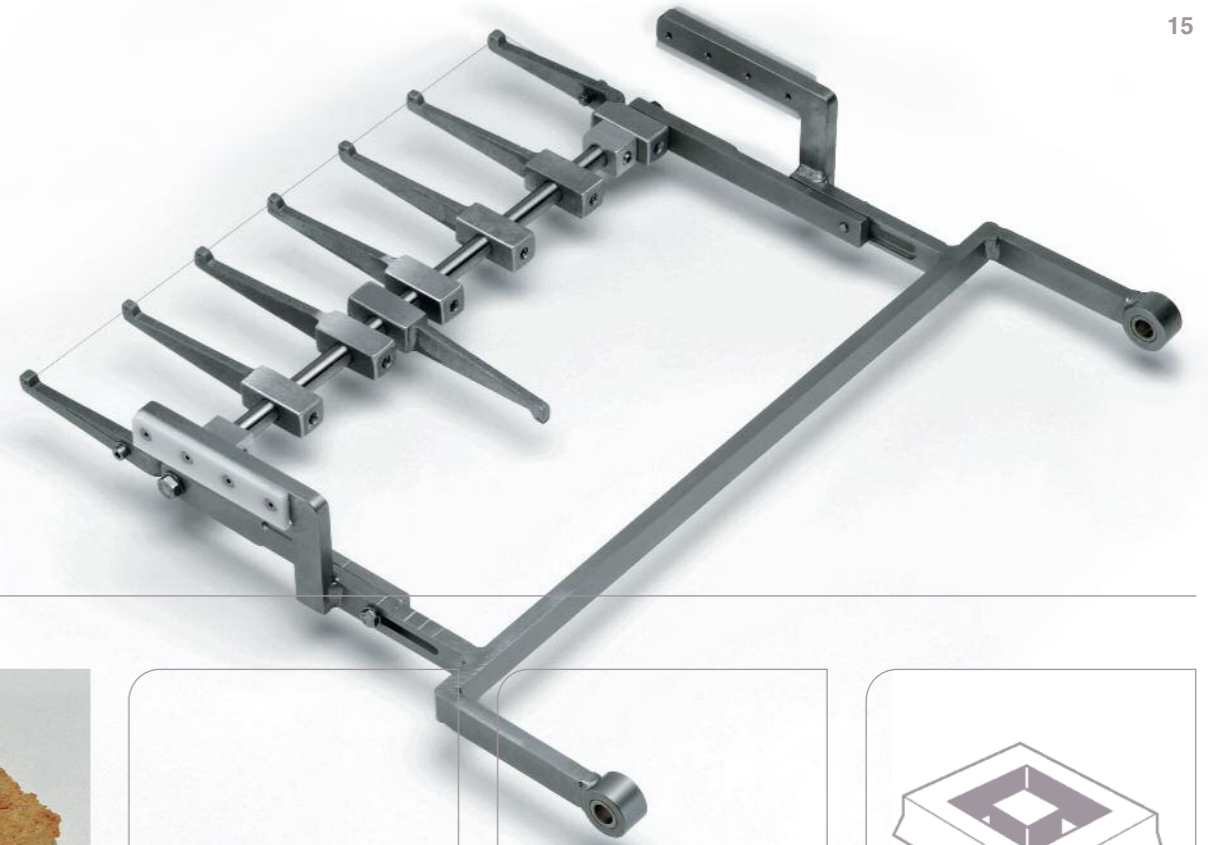
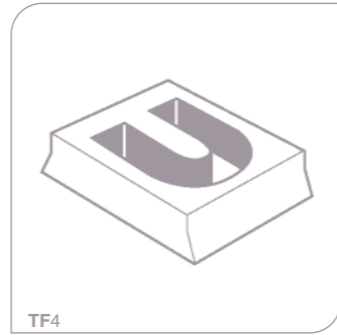
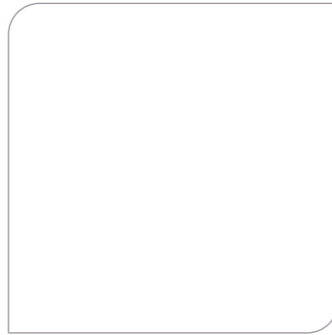
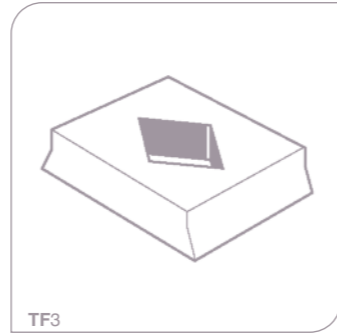
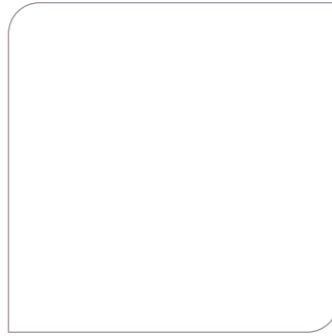
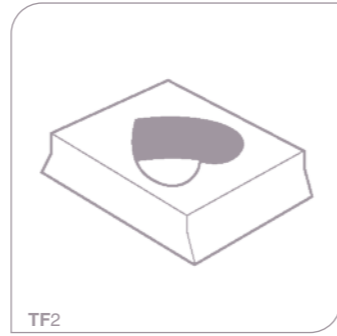
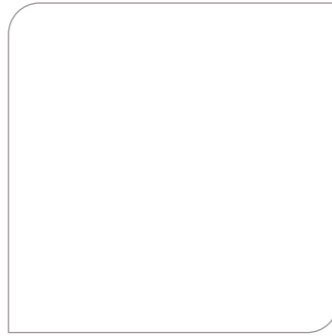
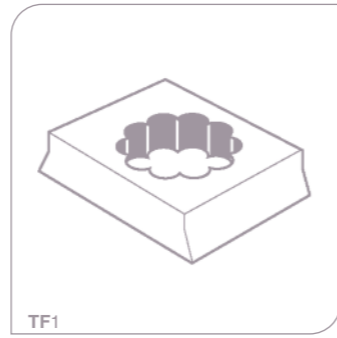
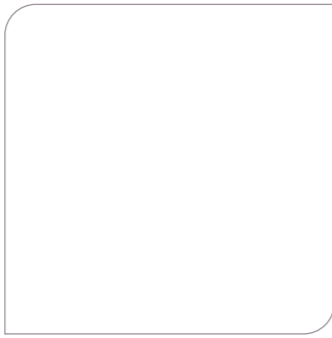

Wire-cut frame

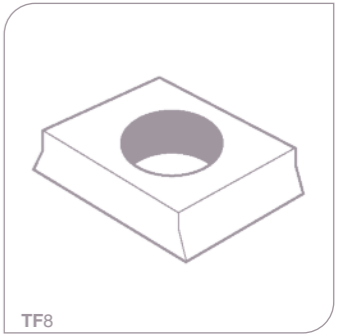
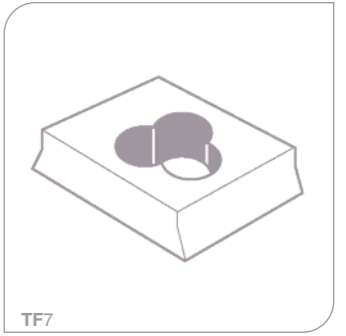
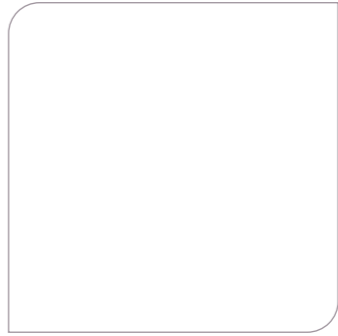
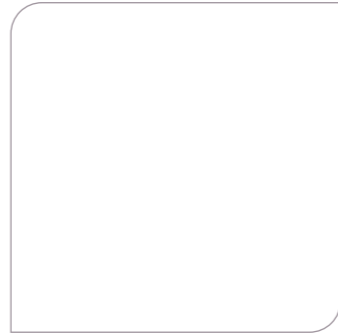
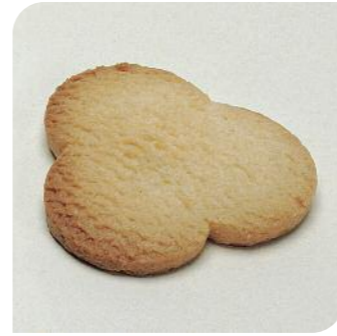
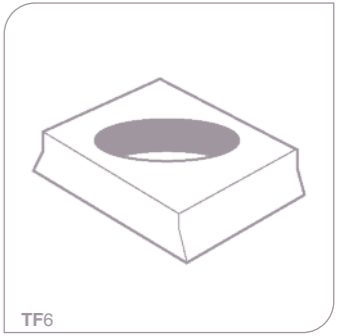
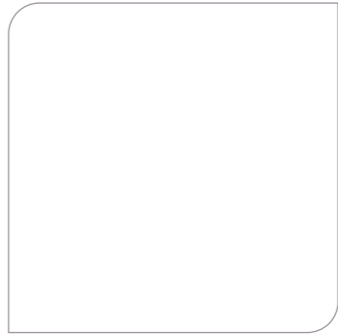
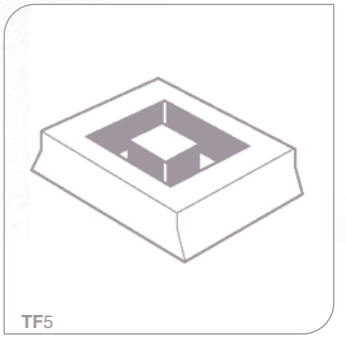
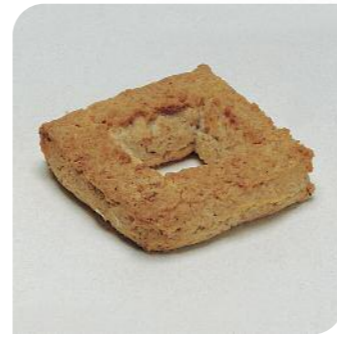





Each COMBY<sup>®</sup> is now available in the new exclusive TF100 version, suitable for wire-cut products up to Ø 100 mm (4 inch)

WIRE-CUT PRODUCTS



Standard mould for dropped products

EXTRUDED PRODUCTS

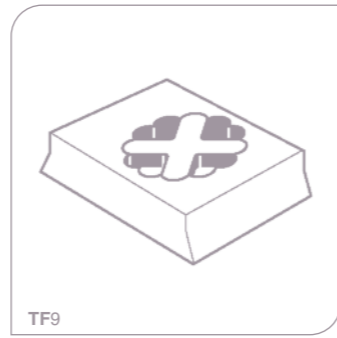

TF9

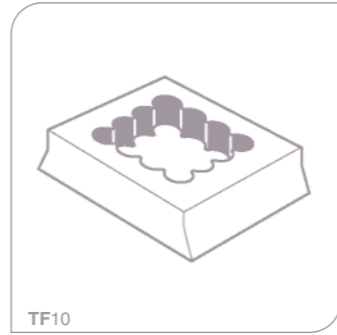
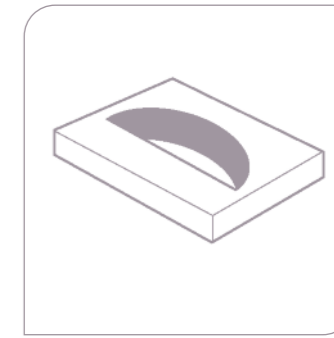

TF10

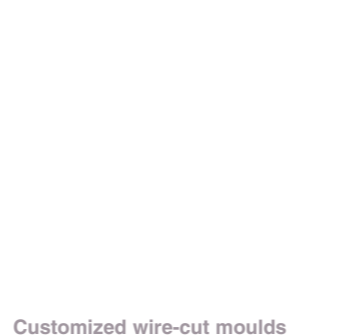
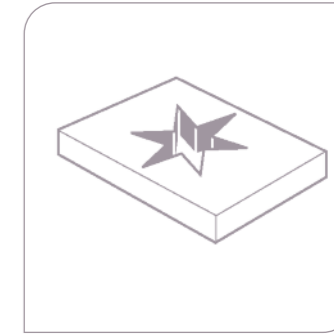

Customized wire-cut moulds

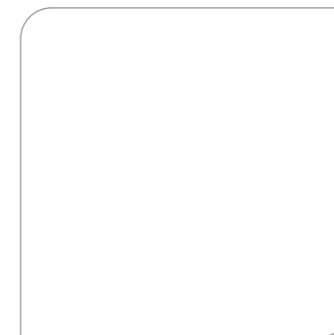
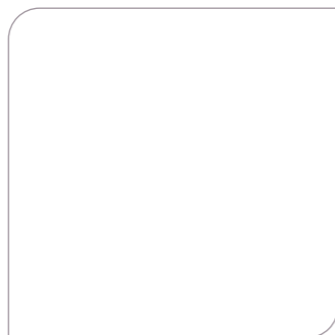
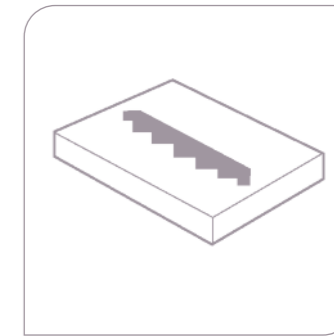
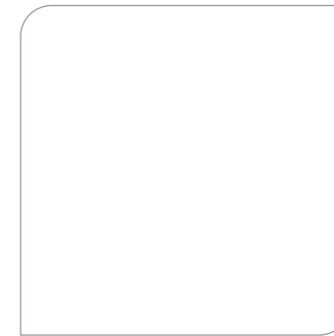
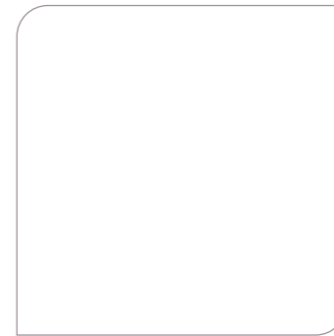

Customized moulds for extruded products: example



## OPTIONALS

COMBY LINE can be completed with customized units: Chocolate chips depositors, Jelly toppers, Sugar sprinkler and many others units for any type of applications.



# COMBY

COMBY. The choice of Buddy Valastro the Cake Boss.

	COMBY <sup>3</sup> SD 400	COMBY <sup>3</sup> SD 460	COMBY <sup>3</sup> SD 600	COMBY <sup>3</sup> PLUS 600
Length (mm)	2610	2610	2610	4500
Width (mm)	851 mm	1036 mm	1096 mm	1096 mm
Height (mm)	1360 mm	1360 mm	1360 mm	1349 mm
Hopper capacity (lt)	27	27	45	50
Installed Power (Kw)	3,2	3,2	3,2	12
Productivity wirecut (bpm)	80	80	80	80
Usefull Width (mm)	400	460	600	600

MINIPAN. TASTE SHAPERS.®



biscuits



bread



bread snacks



gluten free



automation



**MINIPAN**®

industrial lines & machines

MINIPAN® s.r.l. via Trebeghino, 47 - 48024 Massa Lombarda (Ra) - Italy

tel: +39.0545.971593 - fax: +39.0545.971595

web: [www.minipan.com](http://www.minipan.com) - e-mail: [minipan@minipan.com](mailto:minipan@minipan.com)

